

# Eaton SB212812TG

Catalog Number: SB212812TG

Eaton B-Line series runway horizontal to vertical transition kit, 13" height, 13" length, 12" width, ASTM A570 structural steel, Includes transition section, cable support bar, Telco gray powder coat

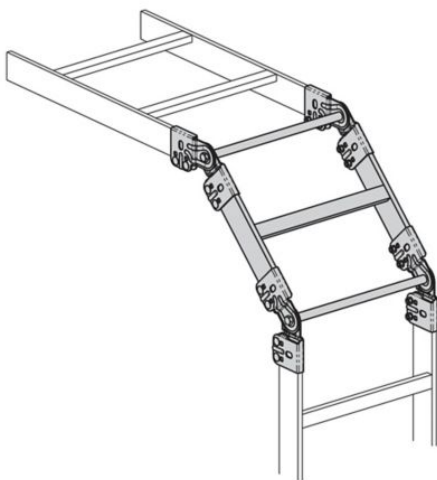

## General specifications

Product Name	Catalog Number
Eaton B-Line series runway horizontal to vertical transition kit	SB212812TG
	UPC
	799038018322
Product Length/Depth	Product Height
13 in	13 in
Product Width	Product Weight
12 in	15.7 lb
Certifications	
UL Classified	

## Product specifications

### Special features

Includes transition section, cable support bar

### Type

Adjustable runway horizontal to vertical transition kit

### Material

Steel

### Material details

ASTM A570 structural steel

### Application

Used for an equipment grounding conductor

## Resources

### Brochures

[Redi-Rail runway brochure](#)

### Catalogs

[Cable runway and accessories section of datacomm catalog](#)

### Specifications and datasheets

[Eaton Specification Sheet - SB212812TG](#)



Eaton Corporation plc  
Eaton House  
30 Pembroke Road  
Dublin 4, Ireland  
Eaton.com  
© 2023 Eaton. All Rights Reserved.

Eaton is a registered trademark.

All other trademarks are property of their respective owners.



[Eaton.com/socialmedia](https://www.eaton.com/socialmedia)